



MULTI-AIM™ SPECIFICATION SHEET

MULTI-AIM PAR30 RECESSED CORNER NEW CONSTRUCTION

LAMPING: 3 x 75 watt max. (short neck)

Cat. No.: L-NW-PAR30L-3 _____ - _____ - _____

Type: _____

Project: _____

Fixture Description:

Recessed 3-light short neck PAR 30, dual inner gimble ring adjustable corner lighting fixture. Housing interior, adjustable lamp assembly and ceiling trims available in satin silver, matte black, and matte white. Special order for other finishes, consult factory. Includes butterfly mounting brackets. Flat hanger bars optional.

Features:

1. **Adjustable flex** for tight spaces above ceiling.
2. **Socket:** Medium base porcelain socket with nickel plated screw shell and SF-1 leads.
3. **Adjustable housing** for 'Mask and Mud' trimless application.
4. **Adjustable inner and outer gimble ring with aiming lock feature.** Outer Ring: 45° lateral tilt. Inner Ring: 40° longitudinal tilt. 360° horizontal adjustment. **Gimble ring color matches housing color.**
5. **16" suspension wire** holds socket box steady for easy below ceiling access.
6. **Junction box** is 16 gauge, 4-in, 4-out branch circuit wiring. UL listed for through branch wiring. Accessible below ceiling.
7. **Thermal protector** meets NEC, UL & cUL requirements.
8. **Adjustable thumb screws** allows vertical adjustment of socket compartment to accommodate ceilings up to 2" thick.
9. **Ceiling trim flange** is mounted to housing with torsion springs.
10. **Butterfly mounting brackets** vertically adjustable from outside of housing.
11. **Die formed fixture frame and housing** constructed of 18 gauge CRS, powder-coated baked enamel finish. Frame-in housing complete with 16 gauge j-box for 4-in, 4-out branch circuit wiring. Fully enclosed wiring compartment.

Notes

All galvanized steel construction available. Consult factory.

Labels

UL / cUL
Suitable for damp location
Chicago Plenum (consult factory)



Bottom View

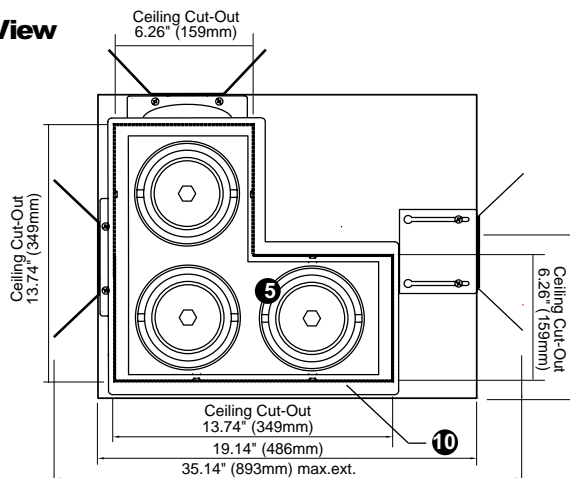

Side View

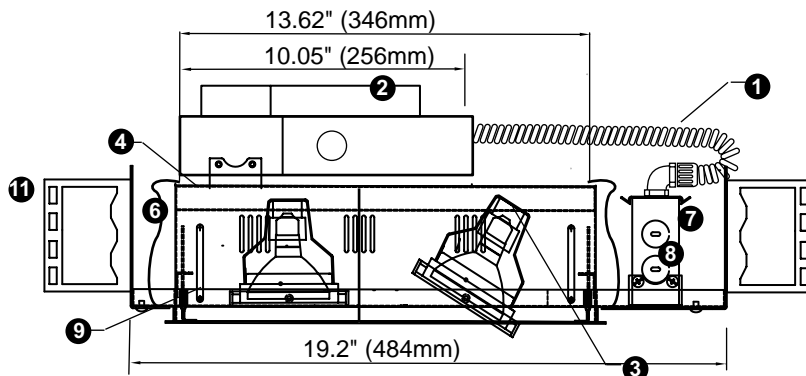

End View Electronic

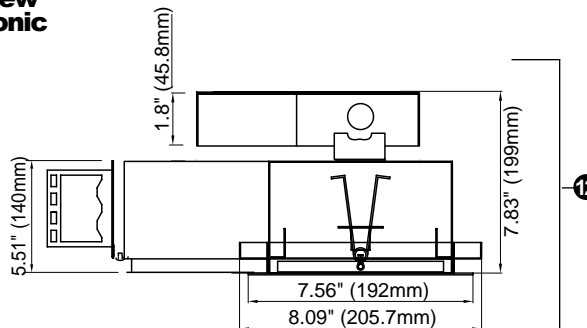

Ordering Information - check appropriate boxes.

Catalog No.

L-NW-PAR30L-3

Housing Finish

HB (Matte Black)

HW (Matte White)

HS (Satin Silver)

Trim Finish

TB (Matte Black)

TW (Matte White)

TS (Satin Silver)

Voltage

1 (120V)

Options

Example: L-NW-PAR30L-3-HS-TS-1

We reserve the right to change specifications without notice.

©2004 Light in Design / Contrast Lighting.

Light in Design **LID** by **CONTRAST** LIGHTING

"When light becomes art"

1009 du Parc Industriel • Saint-Jean-Chrysostome

Quebec, Canada G6Z1C5

Tel.: 418.839.4624 • Fax: 418.839.7057

Toll-free tel.: 1.888.839.4624

www.contrastlighting.com

LNWPAR30L3.4.052204