

# MULTI-AIM™ SPECIFICATION SHEET

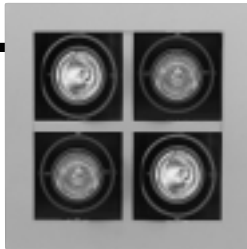

## MULTI-AIM 50W / 71W 4 LIGHT MR16 RECESSED NEW CONSTRUCTION

**LAMPING: 4 x 50W max. (electronic), 4 x 71W max. (magnetic)**

**Cat. No.: L-NW-316E-4E-** \_\_\_\_\_ - \_\_\_\_\_ - \_\_\_\_\_

**Cat. No.: L-NW-316E-4M-** \_\_\_\_\_ - \_\_\_\_\_ - \_\_\_\_\_

Type: \_\_\_\_\_

Project: \_\_\_\_\_

### Fixture Description:

Recessed 4-light MR-16, dual inner gimble ring adjustable square lighting fixture. Housing interior, adjustable lamp assembly and ceiling trims available in satin silver, matte black, and matte white. Special order for other finishes, consult factory. Includes butterfly mounting brackets. Flat hanger bars optional.

### Features:

- Adjustable flex** for tight spaces above ceiling.
- Integral dimmable transformer for each lamp.** Primary lead is 120V. Secondary lead is 11.5V. 277V also available. Consult factory on how this fixture can be used for 347V. 3 year mfg. warranty on electronic and magnetic transformers.
- Socket:** MR16 mini bi-pin with pure nickel contacts. Wire leads: Teflon coated rated at 250°C. **3 year mfg. warranty.**
- Adjustable housing** for 'Mask and Mud' trimless application.
- Adjustable inner and outer gimble ring with aiming lock feature.** Outer Ring: 45° lateral tilt. Inner Ring: 40° longitudinal tilt. 360° horizontal adjustment. **Gimble ring color matches housing color.**
- Lens retaining ring.** Holds up to three lens accessories in place.
- Lampholder caps** allow convenient **front loading** and removal of beam accessories and MR16 lamp. Constructed of die cast aluminum and provides visual glare cutoff. Includes clear UV filtered lens.
- Heavy gauge U steel strap support.**
- 16" suspension wire** holds socket compartment steady for easy below ceiling access. Features 'hands free' maintenance.
- Junction box** is 16 gauge, 4-in, 4-out branch circuit wiring. UL listed for through branch wiring. Accessible below ceiling.
- Thermal protector** meets NEC, UL & cUL requirements.
- Adjustable thumb screws** allows vertical adjustment of socket compartment to accommodate ceilings up to 2" thick.
- Ceiling trim flange** is mounted to housing with torsion springs.
- Butterfly mounting brackets** vertically adjustable from outside of housing.
- Die formed fixture frame and housing** constructed of 18 gauge CRS, powder-coated baked enamel finish. Frame-in housing complete with 16 gauge j-box for 4-in, 4-out branch circuit wiring. Fully enclosed wiring compartment.

### Labels

UL / cUL  
Suitable for damp location

### Bottom View

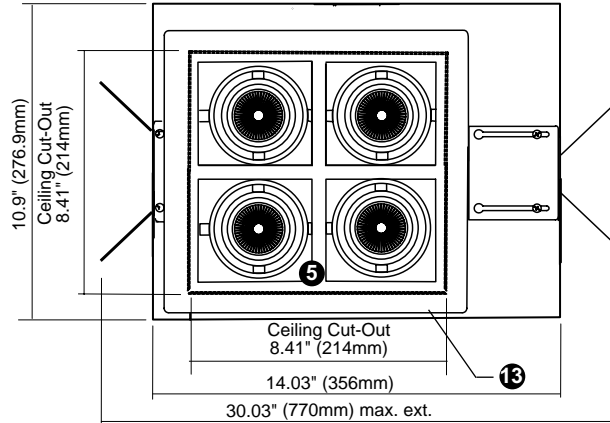

### Side View

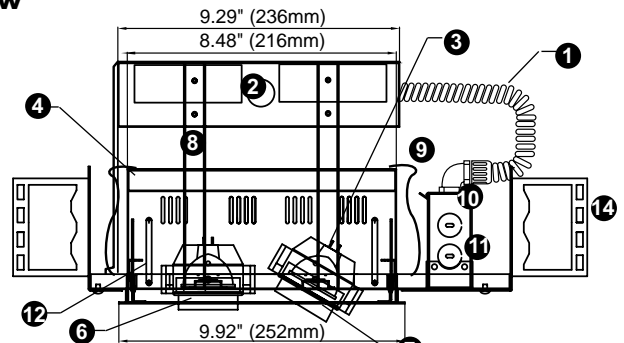

### End View Magnetic

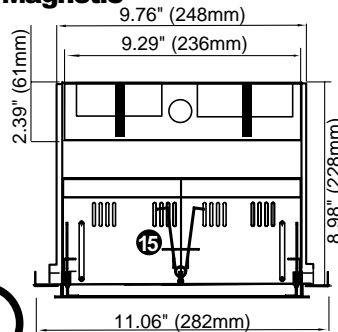

### End View Electronic

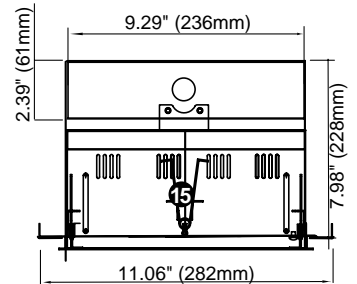

### Ordering Information - check appropriate boxes.

Catalog No.	Transformer	Housing Finish	Trim Finish	Voltage	Options
<input checked="" type="checkbox"/> L-NW-316E-4	<input type="checkbox"/> E (Electronic) <input type="checkbox"/> M (Magnetic)	<input type="checkbox"/> HB (Matte Black) <input type="checkbox"/> HW (Matte White) <input type="checkbox"/> HS (Satin Silver) <input type="checkbox"/> _____	<input type="checkbox"/> TB (Matte Black) <input type="checkbox"/> TW (Matte White) <input type="checkbox"/> TS (Satin Silver) <input type="checkbox"/> _____	<input type="checkbox"/> 120 (120V) <input type="checkbox"/> 277 (277V)	<input type="checkbox"/> _____ <input type="checkbox"/> _____ <input type="checkbox"/> _____

Example: L-NW-316E-4M-HB-TR-120

We reserve the right to change specifications without notice.

©2004 Light in Design / Contrast Lighting.

Light in Design **LID** by **CONTRAST** LIGHTING  
ML Inc.  
"When light becomes art"

1009 du Parc Industriel • Saint-Jean-Chrysostome  
Quebec, Canada G6Z1C5

Tel.: 418.839.4624 • Fax: 418.839.7057

Toll-free tel.: 1.888.839.4624

www.contrastlighting.com

111504