



MULTI-AIM™ SPECIFICATION SHEET

MULTI-AIM PAR30 RECESSED REMODEL

LAMPING: 2 x 75 watt max. (short neck)

Cat. No.: L-IT-PAR30-2 - - -

Type: _____

Project: _____

Fixture Description:

Recessed 2-light PAR30, dual inner gimble ring adjustable lighting fixture for remodel applications. Housing interior, adjustable lamp assembly and ceiling trims available in satin silver, matte black, and matte white. Includes mounting clips.

Features:

1. **Adjustable flex conduit.**
2. **Socket:** Medium base porcelain socket with nickel plated screw shell and SF-1 leads.
3. **Adjustable inner and outer gimble ring.** Outer Ring: 45° lateral tilt. Inner Ring: 40° longitudinal tilt. 360° horizontal adjustment. **Gimble ring color matches housing color.**
4. **Junction box** is 16 gauge, 4-in, 4-out branch circuit wiring. UL listed for through branch wiring. Accessible below ceiling.
5. **Thermal protector** meets NEC, UL & cUL requirements.
6. **Ceiling trim flange** is mounted directly to housing
7. **Locking slot adjustable spring clips** provides for easy installation and accomodates ceilings up to 2" thick.
8. **Die formed housing compartment** constructed of 18 gauge CRS, powder-coated baked enamel finish. Frame-in housing complete with 16 gauge j-box for 4-in, 4-out branch circuit wiring. Fully enclosed wiring compartment.
9. **Fully enclosed wiring compartment.**

Notes

All galvanized steel construction available. Consult factory.

Labels

UL / cUL

Suitable for damp location

Bottom View

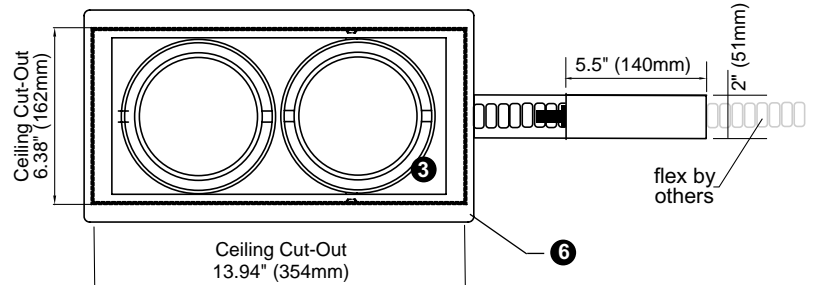

Side View

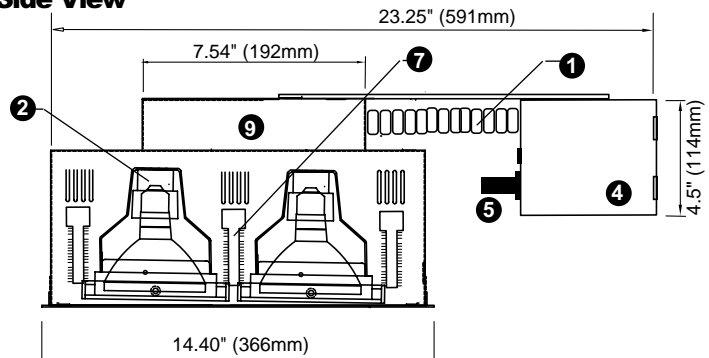

End View

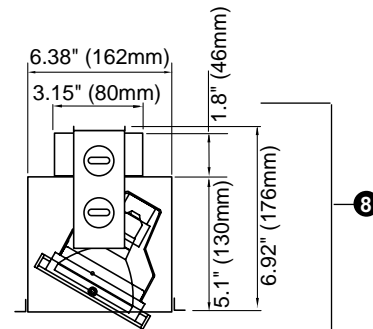

Ordering Information - check appropriate boxes.

Catalog No.

L-IT-PAR30-2

Housing Finish

HB (Matte Black)

HW (Matte White)

HS (Satin Silver)

Trim Finish

TB (Matte Black)

TW (Matte White)

TS (Satin Silver)

Voltage

1 (120V)

Options

Example: L-IT-PAR30-2-HB-TB-1

We reserve the right to change specifications without notice.

©2004 Light in Design / Contrast Lighting.

Light in Design **LID** by **CONTRAST** M.L. Inc.
 LIGHTING
 "When light becomes art"

1009 du Parc Industriel • Saint-Jean-Chrysostome
 Quebec, Canada G6Z1C5
 Tel.: 418.839.4624 • Fax: 418.839.7057
 Toll-free tel.: 1.888.839.4624
 www.contrastlighting.com

LITPAR302.4.052204